



Torque Limiter 820 Series

For more than 80 years, Autogard® products have led the industry in overload protection with high-quality products, design innovation and production. Autogard products are manufactured to meet ISO 9001 using the latest machine tools and high-quality materials.

Acting like a mechanical “fuse” to protect the weakest member of the drive train, the most effective location for Autogard Torque Limiters is as close as possible to the component being protected. The 820 Series has been designed using a modular principle to meet the emerging need for a high-torque, high- and low-speed torque limiter. The trip torque setting can be set to virtually any value depending upon the radius at which the modules are located, the number of modules used and module load setting.

Disengagement on overload

A hardened seat ‘A’ is built into one half of the torque limiter. The module unit is then located into the opposing flange in a way that the torque is transmitted between the plunger ‘B’ and the hardened seat. This produces an end thrust in the plunger in proportion to the applied torque. This force is resisted by a ring of segments ‘C’ trapped between a flat surface and a conical washer loaded by disc springs ‘D.’ When the axial force reaches a level greater than the reaction force through the spring mechanism, the plunger will retract forcing the segments up the plunger slope and allowing the plunger to disengage from the hardened seat. The torque limiter is now allowed to run free. The modular torque limiter may incorporate an optional limit switch plate that moves on trip and can operate a switch to stop the device.

Re-engagement

Resetting is accomplished by simply aligning the two halves, positioning the plunger over the hardened seat, and tapping the reset pin ‘G’ with a soft hammer. An automatic reset version is also available. If required, the trip torque is externally adjusted and is achieved by turning the adjustment nut ‘E’ to increase or decrease the spring pressure.

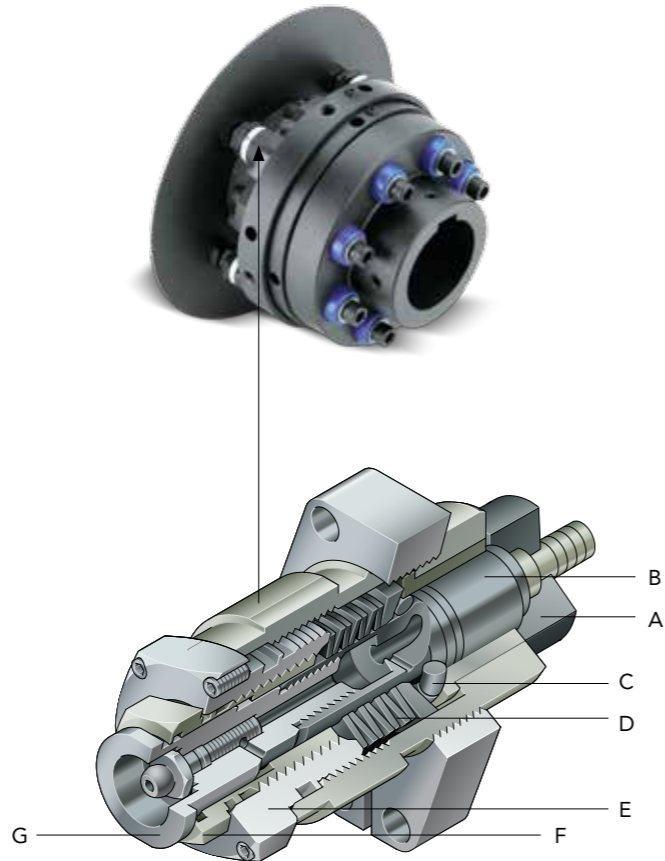

Letters above correspond to paragraphs on the left.

Features and Benefits:

- Accommodates high-torque application with high or low speeds
- Accurate and consistent torque setting ensuring reliable and repeatable torque overload protection
- Instant and complete disengagement of the driving and driven inertias ensuring optimum protection
- Trip torque can be adjusted easily without removing modules from the torque limiter
- Vernier scales are provided on each module allowing for accurate setting of the modules
- In the event of an overload, standard limit switches or proximity sensors can provide automatic motor shutdown
- Modules can be quickly and easily reset — manual or automatic resets available
- Manual disengagement allows for the unit to be disconnected for maintenance purposes
- Integral grease fitting allows for periodic lubrication of the unit without removing it from the drive line
- Wide range of mounting configurations ensures the right solution for any problem
- Drop-out center section allows the torque limiter to be removed from the drive line without moving the equipment

Selection:

Data required for torque limiter selection:

- Application details for service factors
- Kilowatt or horsepower (hp) and rpm of the driver
- Shaft details of the driving and driven equipment

(1) Calculate the nominal torque.

$$\text{Torque (Nm)} = \text{Kw} \times 9550 / \text{rpm}$$

Consideration should then be given to start torque or other special circumstances depending on the position chosen in the drive system. Choose a set torque with a suitable margin over nominal. Select the torque limiter which has a higher torque rating.

(2) Check limiting conditions:

- Check hub bore capacity
- Check the torque limiter dimensions such as the overall length and outside diameter

(3) Select and specify the appropriate drive medium or coupling.

All Autogard 820 Series units may be supplied from the factory at a pre-set torque and with the required drive medium assembled to the unit.

Ordering the 820 Series Torque Limiter

When ordering, please provide the following designation:

Model & Size / Type / S1 Bore / S2 bore.

Standard bore tolerance = H8 + normal fit key

Example: 820-3L / 2 / S1-100 / S2-120

Refers to a 820 Series, size 3L, Type 2 torque limiter

Bore S1 = 100mm Bore S2 = 120mm

Also specify setting torque if required.

The specifications contained within this brochure are correct at the time of going to print. Rexnord is continually reviewing and updating the specifications on its entire Autogard product offering and therefore reserve the right to change any detail.

Any questions? Please contact us.

Morskate Aandrijvingen BV

Oosterveldsingel 47A
7558 PJ Hengelo (Ov)
The Netherlands

NL

T +31 (0)74 - 760 11 11
info@morskateaandrijvingen.nl
www.morskateaandrijvingen.nl

DE

T +49 692 - 222 34 95
info@morskateantriebstechnik.de
www.morskateantriebstechnik.de

EN

T +31 (0)74 - 760 11 11
info@morskatedrivetechnology.com
www.morskatedrivetechnology.com

Type 1

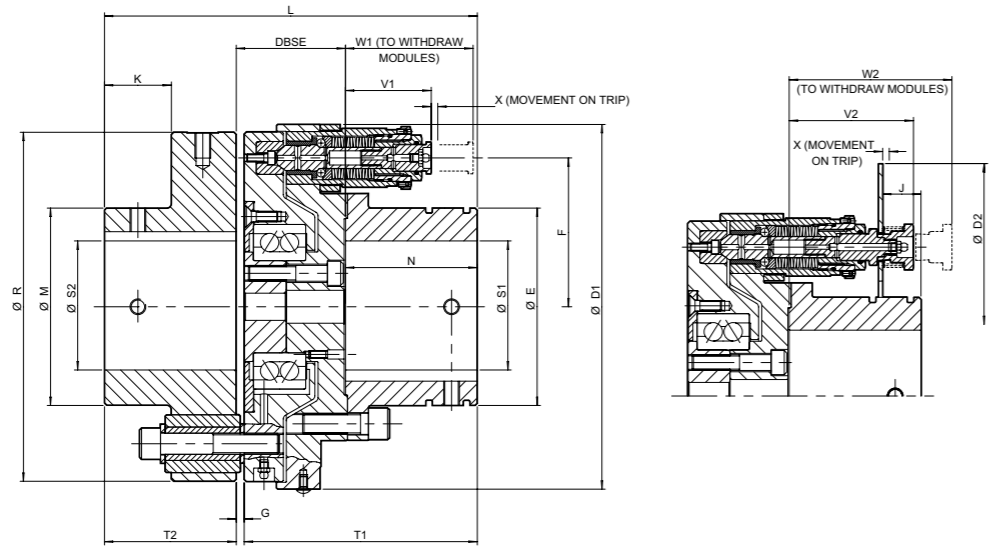

Type 1 Design to accept a standard pin and bush elastic coupling.

Size	S1 (max)	S2 (max)	DBSE	D1	D2	E	F	G	J	K	L	M	N	R	T1	T2	V1	V2	W1	W2	X	
	mm	mm	mm	mm	mm	mm	mm	mm	mm	mm	mm	mm	mm	mm	mm	mm	mm	mm	mm	mm	mm	
1L	80	85	63.2	212	288	115	85.5	6.0	32.6	45.5	223	118.5	80.0	195	137	80.0	50.4	70.8	76.4	93.0	3.7	
1H	80	85	63.2	212	288	115	85.5	6.0	22.6	45.5	223	118.5	80.0	195	137	80.0	60.4	80.8	86.4	103	3.7	
2L	100	115	83.0	277	353	150	113	6.0	43.1	50.8	283	162.5	100	265	177	100	51.1	80.4	84.9	110	5.0	
2H	100	115	83.0	277	353	150	113	6.0	29.1	50.8	283	162.5	100	265	177	100	65.1	94.4	98.9	124	5.0	
3L	120	130	93.4	329	405	180	139	7.0	63.0	60.0	333	188.5	120	314	206	120	51.1	80.4	84.9	110	5.0	
3H	120	130	93.4	329	405	180	139	7.0	49.0	60.0	333	188.5	120	314	206	120	65.1	94.4	98.9	124	5.0	
4L	150	170	114.8	409	485	230	166	7.0	70.0	89.9	415	248.0	150	375	258	150	76.0	109.4	126	131	6.0	
4H	150	170	114.8	409	485	230	166	7.0	46.0	89.9	415	248.0	150	375	258	150	100.0	133.4	150	155	6.0	
5L	180	205	134.8	550	626	280	221	7.0	57.1	119.9	495	310.0	180	470	308	180	118.9	152.3	186	192	8.0	
5H	180	205	134.8	550	626	280	221	7.0	25.1	119.9	495	310.0	180	470	308	180	150.9	184.3	218	224	8.0	
6	230	230																				Designed to customer specification. Please consult Rexnord.

Size ① ②	Modules (Size-Qty)	Torque		Coupling Torque		Max Speed	Mass ③	Mass Moment of Inertia MR ² ④	Max. Axial Misalign.	Max. Parallel Misalign.	
		Min	Max	Nominal	Peak						
		Nm	Nm	Nm	Nm	rpm	kg	kgm ²	mm	mm	
1L	1L-4	370	1,470	2,120	4,240	3800	33.2	0.135	3.0	0.13	
1H	1H-4	735	2,940	2,120	4,240	3800	33.4	0.136	3.0	0.13	
2L	2L-3	860	3,450	6,340	12,680	2400	75.8	0.543	3.0	0.13	
2H	2H-3	1,725	6,900	6,340	12,680	2400	76.2	0.549	3.0	0.13	
3L	2L-4	1,400	5,650	9,650	19,300	2150	124	1.27	3.5	0.13	
3H	2H-4	2,825	11,300	9,650	19,300	2150	125	1.28	3.5	0.13	
4L	3L-4	3,050	12,200	18,070	36,140	1800	244	3.72	3.5	0.13	
4H	3H-4	6,100	24,400	18,070	36,140	1800	246	3.78	3.5	0.13	
5L	4L-3	6,540	26,150	35,000	70,000	1800 ⑤	472	12.6	3.5	0.13	
5H	4H-3	13,075	52,300	35,000	70,000	1800 ⑤	476	12.8	3.5	0.13	
6	5-3	60,000	120,000	Designed to customer specification. Consult Rexnord.							

- ① Max angular misalignment 0.25°.
- ② Balancing optional.
- ③ Consult Rexnord if limit switch plate is required at speeds above 1,400 rpm.
- ④ Mass and inertia values calculated for units with solid hubs without limit switch plate.

820 Series Type 1 Pin Coupling Selection Method

When selecting a 820 Series, Type 1, please confirm the coupling is suitable for the continuous torque, taking into account the duty in which the unit will be used.

- (A) Determine the nominal torque: Torque (Nm) = Kw x 9550 / rpm
- (B) Select the appropriate service factor f_D as shown in Table 1.
- (C) From Table 2 select the factor for the frequency of starts per hour (f_S).
- (D) Determine selection torque: Selection Torque (Nm) = nominal torque x f_D x f_S
- (E) Check to ensure that the coupling's nominal torque rating exceeds the selection torque. If not, select the next larger torque limiter that meets this criteria.

Table 1: Pin coupling service factor (f_D) for 820 Series Type 1 only.

Prime Mover (Drive input)	Driven Machinery Characteristics			
	Duration Service (Hours/Day)	Steady Load	Medium Impulsive	Highly Impulsive
Electric Air, Hydraulic Motors, Steam Turbines (Steady Input)	Intermittent 3 hrs/day max	0.90	1.00	1.50
	3-10	1.00	1.25	1.75
	Over 10	1.25	1.50	2.00
Multi-cylinder I.C. Engine (Medium Impulsive Input)	Intermittent 3 hrs/day max	1.00	1.25	1.75
	3-10	1.25	1.50	2.00
	Over 10	1.50	1.75	2.25
Single-cylinder I.C. Engine (Highly Impulsive Input)	Intermittent 3 hrs/day max	1.25	1.50	2.00
	3-10	1.50	1.75	2.25
	Over 10	1.75	2.00	2.50

Table 2: Pin coupling service Factor (f_S) for 820 Series Type 1 only.

Number of Starts per Hour	0-1	1-30	30-60	60+
Factor	1.00	1.20	1.30	1.50

Notes:
 Service factors are for reference only.
 For applications with excessive vibration, contact Rexnord.
 Rotating equipment must be provided with suitable guarding, or injury may result.

Type 2

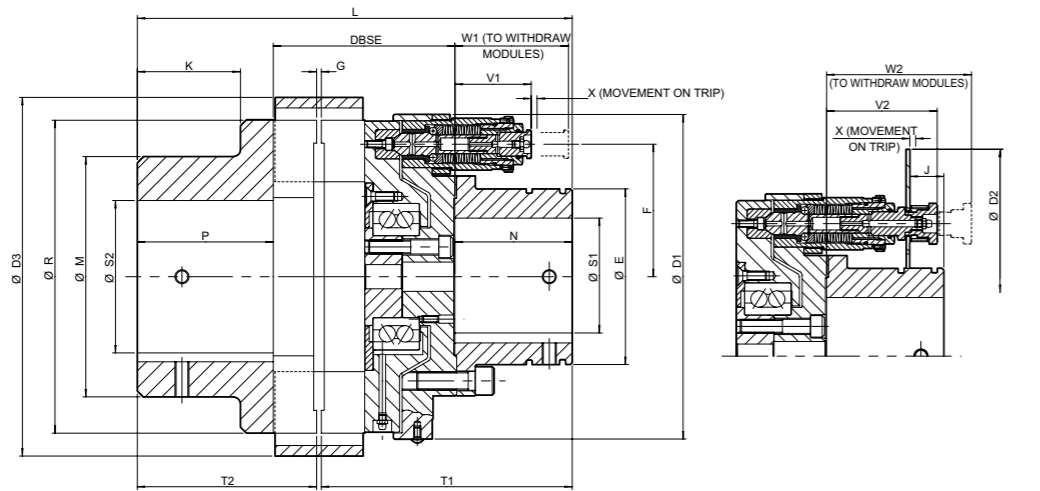

Size ⊙	Modules (Size-Qty)	Torque		Samiflex Coupling Size	Coupling Nominal Torque		Max speed Unbalanced rpm	Max speed Balanced ⊙ rpm	Mass ⊙ kg	Mass Moment of Inertia MR ² ⊙ kgm ²	Max. Axial Misalign. mm	Max. Parallel Misalign. mm	Max. Angular Misalign (degrees)	
		Min	Max		Standard Insert	HD Insert								
		Nm	Nm		Nm	Nm								
1L	1L-4	370	1,470	A6	4,600	6,200	2450	3250	64.5	0.320	+1.0	0.8	1.3	
1H	1H-4	735	2,940	A6	4,600	6,200	2450	3250	65	0.321	+1.0	0.8	1.3	
2L	2L-3	860	3,450	A7	9,200	12,400	2100	2400	95.4	0.757	+1.0	1.0	1.0	
2H	2H-3	1,725	6,900	A7	9,200	12,400	2100	2400	95.9	0.764	+1.0	1.0	1.0	
3L	2L-4	1,400	5,650	A8	17,250	22,400	1750	2150	159	1.78	+1.5	1.0	1.0	
3H	2H-4	2,825	11,300	A8	17,250	22,400	1750	2150	160	1.79	+1.5	1.0	1.0	
4L	3L-4	3,050	12,200	A9	27,500	35,750	1450	1800	271	4.51	+1.5	1.0	1.0	
4H	3H-4	6,100	24,400	A9	27,500	35,750	1450	1800	274	4.58	+1.5	1.0	1.0	
5L	4L-3	6,540	26,150	A11	58,800	76,400	1250	1650 ⊙	537	15.0	+2.0	1.5	1.0	
5H	4H-3	13,075	52,300	A11	58,800	76,400	1250	1650 ⊙	542	15.2	+2.0	1.5	1.0	
6	5-3	60,000	120,000	A12	200,000									Designed to customer specification. Consult Rexnord.

- ⊙ Balancing optional.
- ⊙ Contact Rexnord if limit switch plate is required at speeds above 1,400 rpm.
- ⊙ Steel or ductile iron Samiflex hub.
- ⊙ Mass and inertia values calculated for units with solid hubs and without limit switch plate.

Type 2 design includes the Autogard Samiflex torsionally soft coupling for parallel and angular misalignment.

Size	S1 (max) mm	S2 (max) mm	S2 Pilot mm	DBSE ⊙ mm	D1	D2	D3	E	F	G	J	K	L	M	N	P	R	T1	T2	V1	V2	W1	W2	X	
1L	80	110	39	150.9	212	288	265	115	85.5	3.5	32.6	70	325	180	80	95	233	194	128	50.4	70.8	76.4	92.2	3.7	
1H	80	110	39	150.9	212	288	265	115	85.5	3.5	22.6	70	325	180	80	95	233	194	128	60.4	80.8	86.4	103	3.7	
2L	100	130	48	181.0	277	353	306	150	113	4.0	43.1	88	397	205	100	116	267	240	153	51.1	80.4	84.9	110	5.0	
2H	100	130	48	181.0	277	353	306	150	113	4.0	29.1	88	397	205	100	116	267	240	153	65.1	94.4	98.9	124	5.0	
3L	120	150	63	204.4	329	405	363	180	139	5.0	63.0	114	471	242	120	147	326	278	189	51.1	80.4	84.9	110	5.0	
3H	120	150	63	204.4	329	405	363	180	139	5.0	49.0	114	471	242	120	147	326	278	189	65.1	94.4	98.9	124	5.0	
4L	150	180	73	203.8	409	485	425	230	166	5.0	70.0	129	516	280	150	162	385	303	208	76.0	109.4	125	131	6.0	
4H	150	180	73	203.8	409	485	425	230	166	5.0	46.0	129	516	280	150	162	385	303	208	100.0	133.4	149	155	6.0	
5L	180	210	96	264.8	550	626	503	280	221	6.0	57.1	148	635	350	180	190	458	376	253	118.9	152.3	186	192	8.0	
5H	180	210	96	264.8	550	626	503	280	221	6.0	25.1	148	635	350	180	190	458	376	253	150.9	184.3	218	224	8.0	
6	230	300																							Designed to customer specification. Consult Rexnord.

⊙ Shorter DBSE available using Samiflex Type 'C' hub. Consult Rexnord for details.



820 Series Applications

- Crushers
- Extruders
- Ball Mills
- Chippers
- Conveyor Drives

Type 3

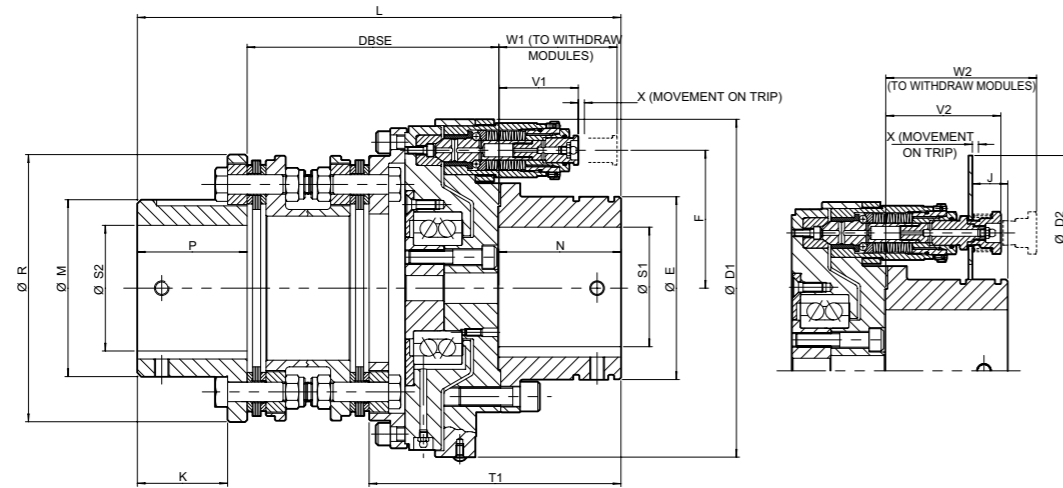

Type 3 design accepts a standard Autoflex ES torsionally rigid coupling.

Size	S1 (max)	S2 (max)	S2 Pilot	DBSE	D1	D2	E	F	J	K	L	M	N	P	R	T1	V1	V2	W1	W2	X
	mm	mm	mm	mm	mm	mm	mm	mm	mm	mm	mm	mm	mm	mm	mm	mm	mm	mm	mm	mm	mm
1L	80	98	25.4	179.3	212	288	115	85.5	32.6	72	349.3	134	80	90	205	159.9	50.4	70.8	76.4	92.2	3.7
1H	80	98	25.4	179.3	212	288	115	85.5	22.6	72	349.3	134	80	90	205	159.9	60.4	80.8	86.4	103	3.7
2L	100	123	50.0	215.0	277	353	150	113	43.1	89	425.1	169	100	110	257	196.3	51.1	80.4	84.9	110	5.0
2H	100	123	50.0	215.0	277	353	150	113	29.1	89	425.1	169	100	110	257	196.3	65.1	94.4	98.9	124	5.0
3L	120	160	50.8	252.0	329	405	180	139	63.0	104	502.0	218	120	130	325	227.3	51.1	80.4	84.9	110	5.0
3H	120	160	50.8	252.0	329	405	180	139	49.0	104	502.0	218	120	130	325	227.3	65.1	94.4	98.9	124	5.0
4L	150	144	25.0	304.1	409	485	230	166	70.0	100	584.1	201	150	130	310	308.1	76.0	109.4	125	131	6.0
4H	150	144	25.0	304.1	409	485	230	166	46.0	100	584.1	201	150	130	310	308.1	100.0	133.4	250	155	6.0
5L	180	188	35.0	355.6	550	626	280	221	57.1	146	710.6	263	180	175	393	364.2	118.9	152.3	186	192	8.0
5H	180	188	35.0	355.6	550	626	280	221	25.1	146	710.6	263	180	175	393	364.2	150.9	184.3	218	224	8.0
6	230	223																			
7	250	258																			
8	300	305																			

Designed to customer specification. Consult Rexnord.

- ⊙ Larger bore available, consult Rexnord.
- ⊙ Values for minimum DBSE shown, longer spacers available upon request.

Size	Modules (Size-Qty)	Torque		Autoflex Coupling Size	Coupling		Mass	Mass Moment of Inertia MR ²	Max. Axial Misalign.	Max. Parallel Misalign.
		Min	Max		Max Continuous Torque	Max speed				
		Nm	Nm		Nm	rpm				
1L	1L-4	370	1,470	HVII 330-6	3,300	3800	47.4	0.214	1.79	0.77
1H	1H-4	735	2,940	HVII 330-6	3,300	3800	47.7	0.216	1.79	0.77
2L	2L-3	860	3,450	HVII 700-6	7,000	2400	91.6	0.677	2.29	0.90
2H	2H-3	1,725	6,900	HVII 700-6	7,000	2400	92.0	0.683	2.29	0.90
3L	2L-4	1,400	5,650	HVII 1300-6	13,000	2150	170	1.87	2.89	1.09
3H	2H-4	2,825	11,300	HVII 1300-6	13,000	2150	171	1.88	2.89	1.09
4L	3L-4	3,050	12,200	HVII 2500-8	25,000	1800	303	4.29	6.08	0.73
4H	3H-4	6,100	24,400	HVII 2500-8	25,000	1800	306	4.36	6.08	0.73
5L	4L-3	6,540	26,150	HVII 4420-8	48,880	1800	537	14.0	7.91	0.79
5H	4H-3	13,075	52,300	HVII 4420-8	48,880	1800	541	14.2	7.91	0.79
6	4H-4	47,400	94,800	HVII 7240-8	72,400					
7	5-3	78,750	157,500	HVII 11660-8	116,600					
8	5-3	120,000	240,000	HVII 20000-8	200,000					

Designed to customer specification. Consult Rexnord.

- ⊙ Max angular misalignment 1/2° per flexing pack sizes 1 to 3, 1/3° per flexing pack for unit sizes 4 and 5.
- ⊙ Consult Rexnord if limit switch plate is required at speeds above 1,400 rpm.
- ⊙ Mass and inertia values calculated for units with solid hubs, minimum DBSE and without limit switch plate.



Type 4 and Type 5

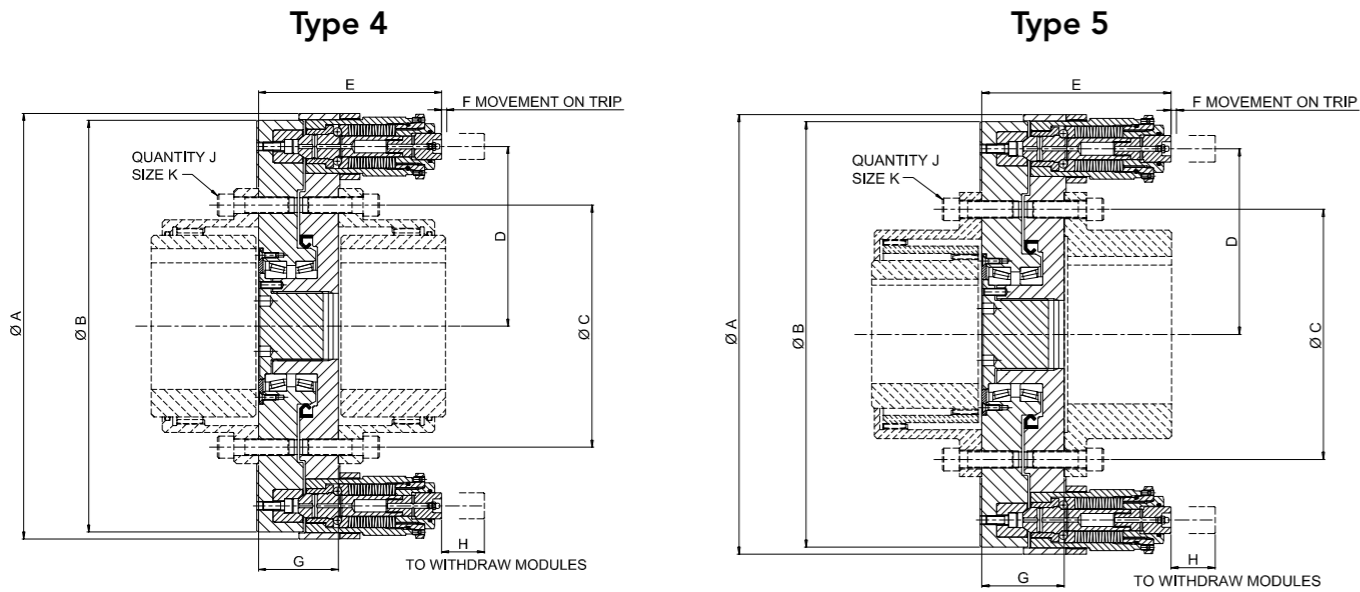

Size	Modules (Size-Qty)	Torque				Mass [⊙] kg	Mass Moment of Inertia MR ² [⊙] kgm ²
		Min	Max	Max speed Type 4 [⊙]	Max speed Type 5 [⊙]		
		Nm	Nm	rpm	rpm		
2.5	2H-4	2,800	10,900	1900	3000	55	0.62
3.0	2H-4	3,000	12,000	1700	2700	63	0.82
3.5	2H-6	5,100	20,400	1500	2400	84	1.97
4.0	3H-4	7,400	29,400	1200	2000	153	4.21
4.5	3H-6	11,800	47,200	1200	1800	177	5.57
5.0	3H-8	17,300	69,100	1200	1800	218	8.06
5.5	4H-4	21,300	85,200	1000	1500	359	17.98
6.0	4H-6	33,800	135,100	900	1400	411	23.01
7.0	4H-6	37,900	151,600	900	1300	494	33.57
8.0 to 11.0	↓	↓	↓	Designed to customer specification. Consult Rexnord.			
12.0	5-10	375,000	750,000				

[⊙] Balancing may allow up to 50 percent increase in speeds shown. Please consult Rexnord.
[⊙] Mass and moment of inertia values excluding gear coupling.

Type 4 designed to accept standard full flex AGMA gear couplings.

Type 5 designed to accept standard double engagement half flex AGMA gear couplings.

Size	AGMA Gear Coupling Size [⊙]	A	B	C	D	E	F	G	H	J	K
		mm	mm	mm	mm	mm	mm	mm	mm	mm	in
2.5	2.5	318	306	181.0	133.5	165	5	106	34	6	5/8
3.0	3.0	345	333	206.4	147.0	165	5	106	34	8	5/8
3.5	3.5	385	373	241.3	166.9	165	5	112	34	8	3/4
4.0	4.0	476	461	279.4	200.0	208	6	112	50	8	3/4
4.5	4.5	504	488	304.8	214.0	214	6	112	50	10	3/4
5.0	5.0	546	530	342.9	234.9	217	6	117	50	8	7/8
5.5	5.5	648	612	368.3	269.7	292	8	147	68	14	7/8
6.0	6.0	678	643	400.1	285.1	292	8	147	68	14	7/8
7.0	7.0	748	712	463.6	320.0	292	8	147	68	16	1.00
8.0 to 11.0	8.0 to 11.0	Designed to customer specification. Consult Rexnord.									
12.0	12.0										

[⊙] The 820 Type 4 and Type 5 Torque Limiters can be supplied with or without the gear coupling. Please advise at time of order.

Type 6

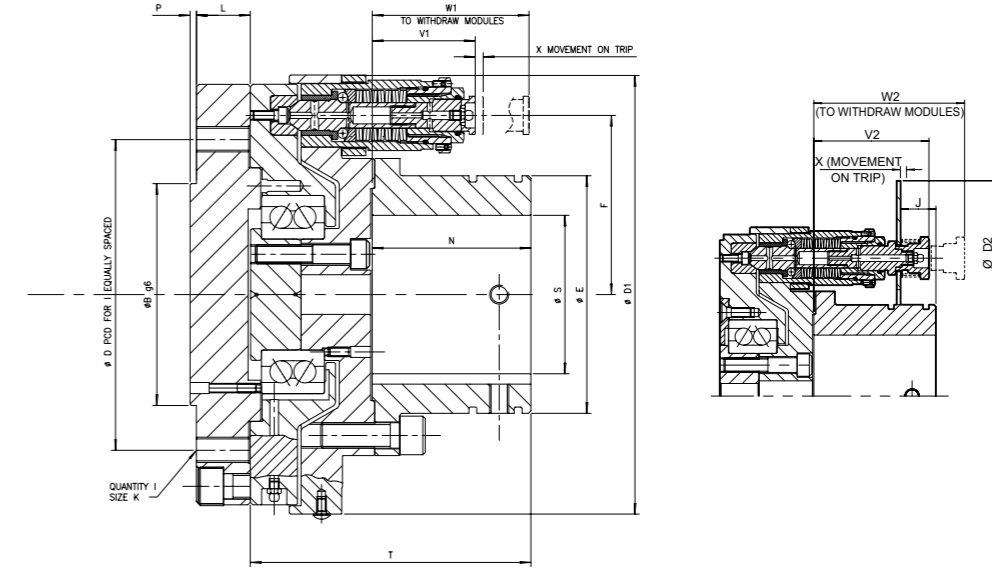

Size	Torque		Flange size mm	Max Speed rpm	Weight kg	Max Angular Misalignment degrees	Max Axial Load kN	Max radial load N	Mass Moment of Inertia [⊙] kgm ²
	Min	Max							
	Nm	Nm							
2H	1,725	6,900	180	1800	60.9	5	28	200	0.5
			225	1800	60.9	5	28	200	0.5
3H	2,825	11,300	225	1800	99.5	5	40	620	1.16
			285	1800	99.5	5	40	620	1.16
4H	6,100	24,400	285	1800	201.5	5	58.5	1080	3.56
			315	1800	201.5	5	58.5	1080	3.56
5H	13,075	52,300	350	1800 [⊙]	323	5	96	2450	11.13
			390	1800 [⊙]	323	5	96	2450	11.13

[⊙] Mass and inertia values calculated for units with solid hubs and without limit switch plate
[⊙] 1800 rpm without the switch plate otherwise 1400rpm

Size	Flange size mm	B	D PCD	D1	D2	E	F	I	J	K	L	N	P	Max S	T	V1	V2	W1	W2	X
		mm	mm	mm	mm	mm	mm	mm	mm	mm	mm	mm	mm	mm	mm	mm	mm	mm	mm	mm
2H	180	110	155.5	277	353	150	113	8	29.1	M14	33	100	3	100	177	65.1	94.4	98.9	124	5
	225	140	196	277	353	150	113	8	29.1	M16	33	100	5	100	177	65.1	94.4	98.9	124	5
3H	225	140	196	329	405	180	139	8	49	M16	40	120	5	120	206	65.1	94.4	98.9	124	5
	285	175	245	329	405	180	139	8	49	M20	40	120	6	120	206	65.1	94.4	98.9	124	5
4H	285	175	245	409	485	230	166	8	46	M20	44	150	6	150	258	100	133.4	150	155	6
	315	175	280	409	485	230	166	8	46	M22	44	150	6	150	258	100	133.4	150	155	6
5H	350	220	310	550	626	280	221	10	25.1	M22	⊙	180	7	180	308	150.9	184.3	218	224	8
	390	250	345	550	626	280	221	10	25.1	M24	⊙	180	7	180	308	150.9	184.3	218	224	8

[⊙] No adaptor required

Module Sub Assemblies

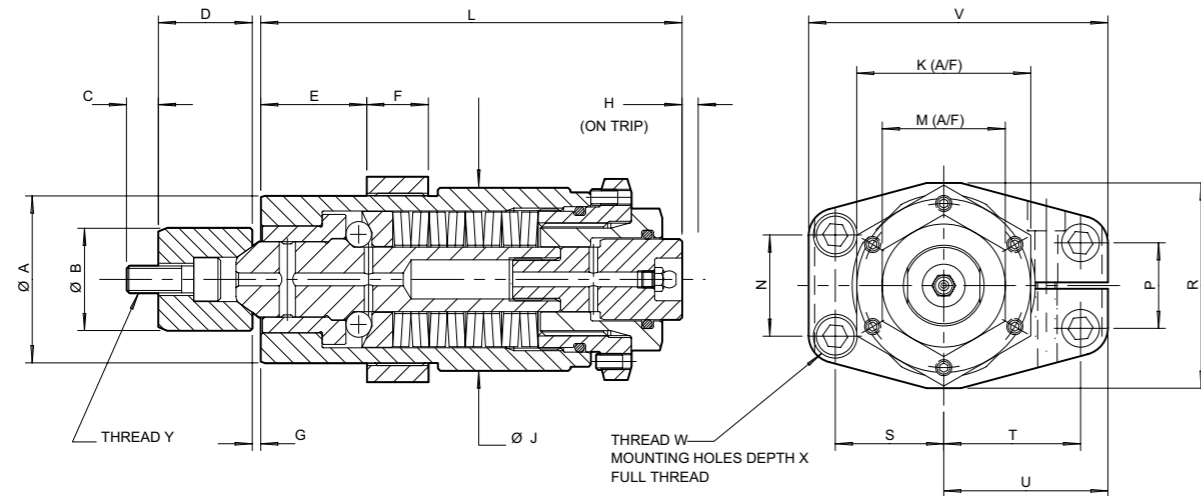

Autogard 820 Series module sub assemblies may be designed into customer specific applications. Consult Rexnord for assistance.

Size	Tangential Force		Axial Force		Mass ⊙ kg
	Min N	Max N	Min N	Max N	
1L	1,075	4,300	538	2,150	0.49
1H	2,150	8,600	1,075	4,300	0.55
2L	2,550	10,200	1,275	5,100	1.05
2H	5,100	20,400	2,550	10,200	1.19
3L	4,600	18,400	2,300	9,200	3.78
3H	9,200	36,800	4,600	18,400	4.39
4L	9,875	39,500	4,938	19,750	9.14
4H	19,750	79,000	9,875	39,500	10.64
5	75,000	150,000	37,500	75,000	18.50

⊙ Mass includes mounting screws and seat bush.

Size	A (g7/H7) mm	B (h7/H7) mm	C mm	D mm	E mm	F mm	G mm	H mm	J mm	K mm	L mm	M mm	N mm	P mm	R mm	S mm	T mm	U mm	V mm	W mm	X mm	Y mm
1L	30	18	8.3	13.2	19.6	11.4	1.7	3.7	33.3	30	83.4	24	18.80	14.73	39.6	19.81	26.16	31.0	55.6	M5	15	M4
1H	30	18	8.3	13.2	19.6	11.4	1.7	3.7	33.3	30	93.4	24	18.80	14.73	39.6	19.81	26.16	31.0	55.6	M5	15	M4
2L	40	25	11.0	17.1	25.6	15.2	2.3	5.0	44.5	41	95.9	30	24.13	16.51	50.8	25.91	32.26	38.1	69.9	M6	16	M6
2H	40	25	11.0	17.1	25.6	15.2	2.3	5.0	44.5	41	109.9	30	24.13	16.51	50.8	25.91	32.26	38.1	69.9	M6	16	M6
3L	62	38	15.9	26.9	39.4	22.9	3.1	6.0	68.0	65	132.6	46	37.59	31.75	76.2	40.28	50.80	61.0	111.1	M10	25	M10
3H	62	38	15.9	26.9	39.4	22.9	3.1	6.0	68.0	65	156.6	46	37.59	31.75	76.2	40.28	50.80	61.0	111.1	M10	25	M10
4L	85	48	19.9	33.0	54.0	25.4	3.8	8.0	92.0	⊙ 92	184.0	65	57.15	43.18	108.0	49.53	68.58	80.0	141.0	M12	32	M12
4H	85	48	19.9	33.0	54.0	25.4	3.8	8.0	92.0	⊙ 92	216.0	65	57.15	43.18	108.0	49.53	68.58	80.0	141.0	M12	32	M12
5	105	70	33.0	47.3	54.0	50.0	5	12	105.0	⊙ 105	204.0	-	98.99	98.99	134.0	49.50	49.50	85.0	170.0	M16	43	M16

⊙ ⌀ Adjusting nuts are round. Dimension shown is the diameter.

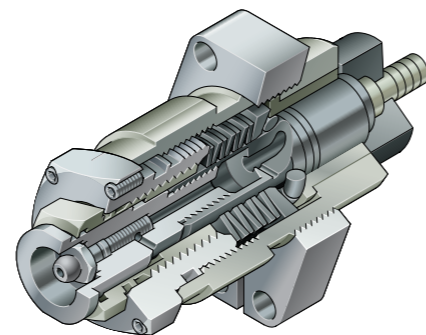

Special Designs

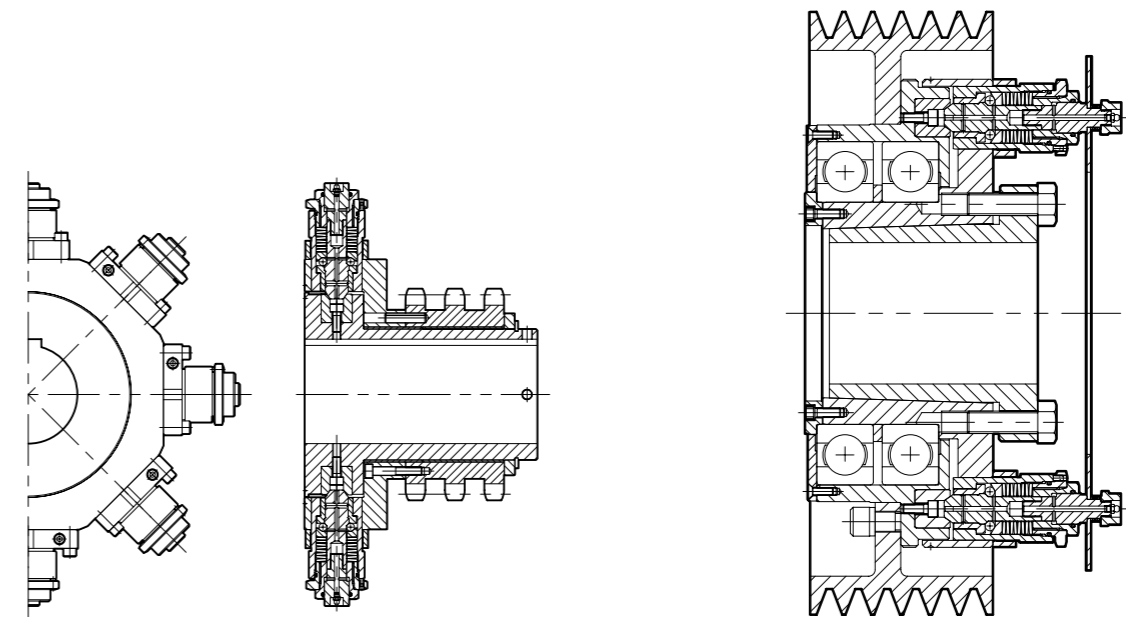

Radial Module with Triplex Sprocket
Designed for tight axial space constraints

Standard 820 Series with pulley
Designed for v-belt pulley applications

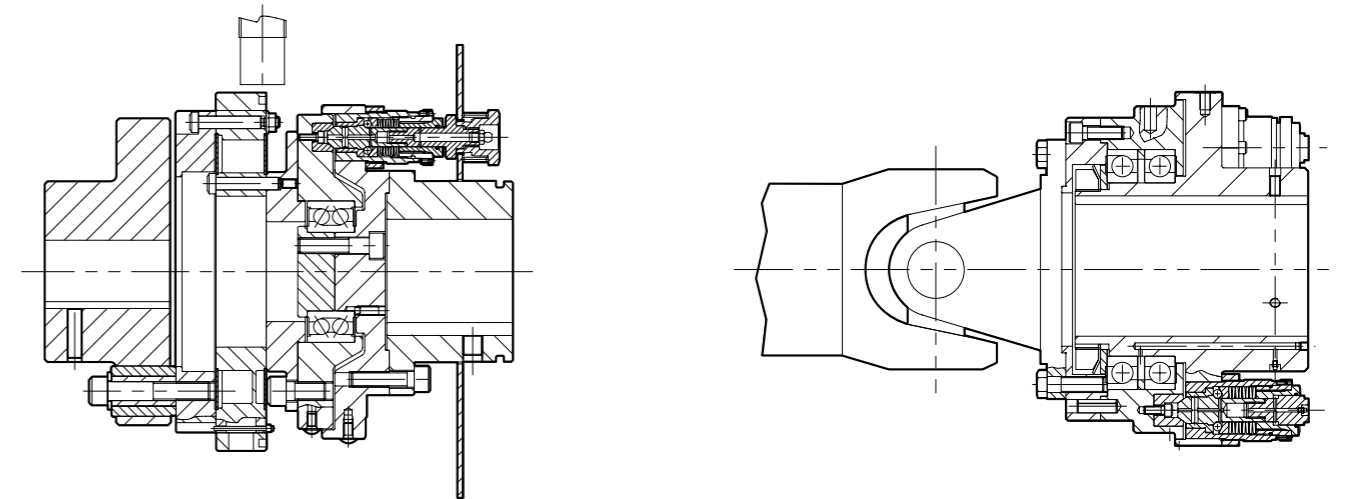

Standard 820 Series with Monitorq™ Torque Monitoring Equipment
Designed for overload protection and condition monitoring

820 Series Type 6
Designed to accept standard universal joint couplings